

SKWOOSH™ MOTORCYCLE GEL PAD

SKWOOSH™

Goldwing motorcycle riders who want touring comfort and support, without bulk now enjoy the same Gel seat benefits as performance athletes and commercial pilots. By relieving pressure on the weight bearing "sitz" bones, patented TekPad® gel allows a motorcycle rider to travel miles without discomfort, loss of circulation and numbness. The SKWOOSH™ Motorcycle Gel Touring Pad weighs 13 ounces and it folds for easy storage. A NON-SKID bottom keeps the gel seat from moving during use so there's no need for straps, buckles or cords. Positive testimonials from people who do long and short rides on all types and sizes of bikes say "if you want to sit comfortably and enjoy your ride more, you need a SKWOOSH™ Gel seat".



CUSHIONING - TekPad lightweight pressure relieving gel
COMFORTABLE - Relieving pressure helps you ride longer
COMPACT - Folds to 8" x 13" for easy saddle bag storage
LIGHTWEIGHT - Portable - only 13 ounces
LOW PROFILE - Maintains CG for better stability - no adjustments
FIT - Unique folding desing Model# M1104 fits Goldwing1800
INTEGRATED NON-SKID BOTTOM - Stays put - No buckles or straps
MAINTENANCE FREE - No washing - functions in all temperatures
WATERPROOF - never soggy - won't mold
DURABLE LOW FRICTION COVER MATERIAL - NO Rubbing
ALL WEATHER GEL - Stays soft in all temperatures

SKWOOSH™ Motorcycle Gel Pad (Model# M1104) Description

Weight: 13 oz.

Dimensions: 13" x 16" x 7/8" flat, 13" x 8" x 1 3/4" folded
70d low friction cover. Integrated non-skid bottom.
Folds for storage. Maintenance free.

- a. TekPad® bladder welded in two sections
- b. 3/4" nylon ribbon binding
- c. Nylon cord tie down loop
- d. Non-Skid Bottom
- e. 70 denier waterproof nylon cover
- f. 3/4" TekPad® bladder
- g. Cross Linked Foam

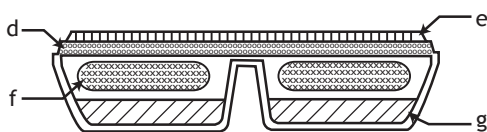
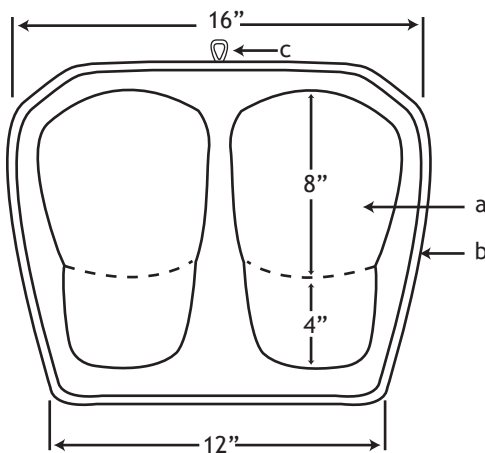

cross sectional view

Performance Comfort Cushions
sports / office / travel



SKWOOSH IS DIFFERENT

Patented TekPad Technology
packs giant Comfort into a
convenient package

*NOT TO BE USED FOR FLOATATION

Contact Us!

Ph: 978.689.0500 Fax: 978.689.7771

email: info@skwoosh.com or visit: www.skwoosh.com